



TTM Series Micro Switch



Features

Compact detector switches for micro-current circuit.

Applications :

Compact audio products, office machines, compact radio equipments, VCRs, video camera recorders, etc.

Specifications

Rating	500mA 12VDC	Mechanical Life	30,000 cycles
Contact Resistance	100mΩ Max.	Electrical Life.	20,000 cycles
Insulation Resistance	>100MΩ DC250V	Ambient Temper. Used	-25°C to 85°C
Withstand Voltage	AC500V 1min.	Ambient Humidity Used	<85% RH
Soldering Temper.	260 5°C 3s	Operating Force	50gf Max.

1562374352000

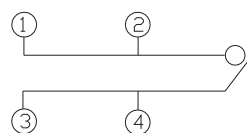
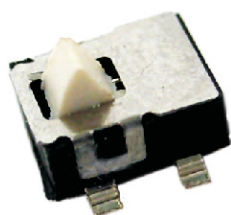

Circuit diagram

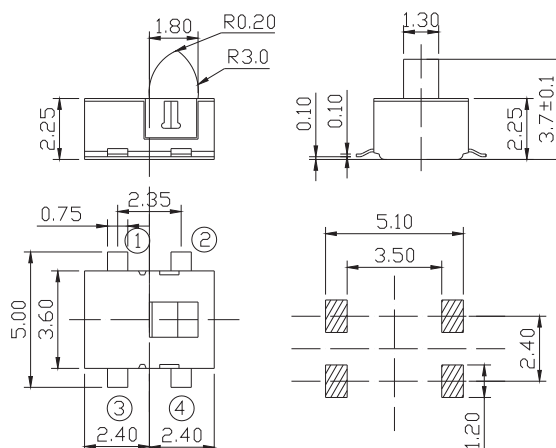

Pad layout

1561853351000

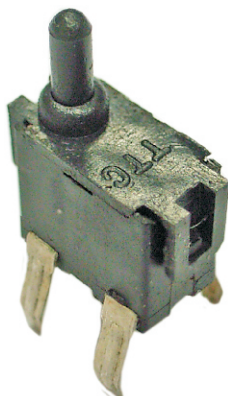

SCHMATIC

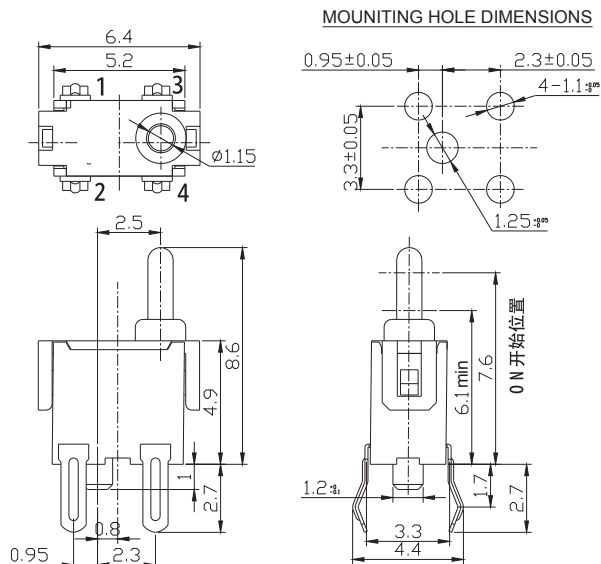
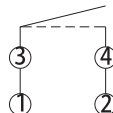

MOUNTING HOLE DIMENSIONS

